

# Virtual engineering of a naval weapon system based on the heterogeneous simulation implemented through the MBSE

Eugenio Brusa  
Dept. of Mechanical and Aerospace  
Engineering  
Politecnico di Torino  
Torino, Italy  
eugenio.brusa@polito.it

Davide Ferretto  
Dept. of Mechanical and Aerospace  
Engineering  
Politecnico di Torino  
Torino, Italy  
davide.ferretto@polito.it

Jean Michel Cervasel  
Dept. of Mechanical and Aerospace  
Engineering  
Politecnico di Torino  
Torino, Italy

**Abstract**— The Model Based Systems Engineering (MBSE) is effectively applied to develop a naval gun system, actively controlled for the target tracking, and to control the effect of ship dynamics. A commitment, usually written by a Department of Defense, requires to include in the trade-off analysis the investigation of both the system configuration and dynamic behavior. The use of interoperated functional and physical models, based on the SysML language, allow the customer getting a realistic impression of the system geometry and of its controlled dynamics, when the MBSE heterogeneous simulation is performed. To enable that simulation, the geometrical and numerical models are built and linked to the functional models, even by resorting to the architecture frameworks, deeply detailed by the customer. A test case is herein proposed, to provide an example of full mechatronic system integration and simulation, through the creation of a virtual mock-up.

**Keywords**—Structural mechatronics, Virtual engineering, MBSE, Interoperability, Dynamic simulation, Heterogeneous simulation.

## I. INTRODUCTION

The development of a *smart product* as a weapon system includes some crucial tasks, like the elicitation of requirements, usually based on a very specific commitment of a Department of Defense, expressing the customer needs; the decomposition of the system complexity, motivated by a number of subsystems, interfaces and components; the prediction of system dysfunctions, and the related assessment of system safety and reliability [1]. Those exigencies drive the industry to implement the *Model Based Systems Engineering* (MBSE) to link requirements, functional and numerical analyses of the system, to be designed and manufactured [2]. This approach allows the *allocation* of requirements to functions, then of functions to the system components and to *trace* completely the whole product life cycle development [3].

In case of naval constructions, for defense purpose, the commitment document is written by the Department of Defense, of a given country, often in tight collaboration with operative units, like the Navy [4]. The contents must be exhaustive, unambiguous and sufficiently clear to suitably drive the manufacturer through a *trade-off* of the system layout. This document is complete and precise, but a *common language* between customer and manufacturer is needed, as well as a *clear pattern* to be followed in the product development, to fit all the requirements of safety, performance, quality, cost and delivery (QCF) and those of some technical standards. Moreover, the customer wants to have a preliminary overview of the system capabilities, based

on a virtual representation of the system in operation, i.e. a *virtual mock-up*, and a *heterogeneous simulation* of its functions [5]. Therefore, a suitable integration between commitment, functional and physical models is strictly required [6].

That need is coped by the MBSE, and the SysML language [7] can be used to perform a preliminary assessment of requirements, and a *trade-off* of the system architecture. A *numerical modeling* is then linked to the functional models, as it is herein developed, through the SOLIDWORKS®, SIMSCAPE® and SIMULINK® tools. This activity leads to a preliminary impression of the overall system architecture, functions, and dynamic behavior, i.e. it provides the required *virtual mock-up*. An efficient *interoperability of tools* is required, to assure the effectiveness of the MBSE, expressively in this technical domain, where the verification of requirements is performed, upon the contents of the commitment document [8].

As the test case demonstrates, those needs are applied, in general, to many mechatronic systems. Therefore, the use of integrated geometrical, dynamic (both physical) and functional simulators for the *heterogeneous simulation* [9] is here proposed and discussed, for a wider application in systems dynamics and control. The focus of this paper is investigating the *methodology* applied to interoperate and using some useful tools, for the above mentioned design analysis. For this purpose, a real test case is analyzed, thanks to the collaboration with an industrial partner.

## II. THE NAVAL WEAPON SYSTEM

The system is a naval gun for cruisers, destroyers and frigates ships, similar to the Mk45 [10], although this is just another product available on the market.

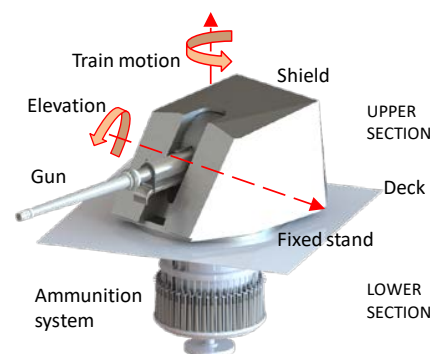

Fig. 1. Example of impression of a typical naval gun architecture.

Some nondisclosure restrictions impose to limit the information herein shared, about some figures and parameters, although the main goal here is describing how the heterogeneous simulation can be effectively used, to improve the design activity, more than emphasizing the performance of the specific commercial product.

The *Naval Gun System*, or NGS, as it shall be herein called, is a subsystem of a navy ship. It provides a weapon system against surface, land and air targets, being conceived to operate under all the operating environments and sea conditions, and to assure a high accuracy in *training* and *elevation motion* rates, as well as a rapid response to the *operator command* [4].

A main innovation target is currently to operate this system *automatically* and *remotely*, without a direct crew member interaction, with a very high reliability in terms of operation and lethality. The NGS control basically drives two motions, a *yaw* about the vertical axis through the so-called *training motion*, and the gun *elevation* about an horizontal axis (Fig.1). Usually the architecture includes a lower section, where the fixed part, constrained to the ship deck, and the ammunition system are located, and an upper section, where the carriage, including all the mechanical components of the gun, the shield, the training and elevating masses are installed, together with the cradle, for recoiling motion [4,5].

### III. THE COMMITMENT CONVERTED INTO A FUNCTIONAL MODEL

A first novelty, recently introduced in this technical domain, consists in applying the MBSE to the NGS commitment. Usually, this document defines all the requirements of the new system, through a written technical specification. It takes time to be written, it does not allow a real exploration of alternative solutions, since a given architecture is assumed, to define the requirements. Sometimes, it looks ambiguous, if it is based on a verbal report, whose style depends quite a lot upon the communication skills of the committing customer. Therefore, the *architecture frameworks*, like the DoDAF (US Dept. of Defense Architecture Framework) [11], MODAF (UK) [12] and NAF (NATO) [13] suggest a set of standard *views* (for instance, strategic, system, operational, technical and acquisition views), to define the mission, scenarios and capabilities of the committed system.

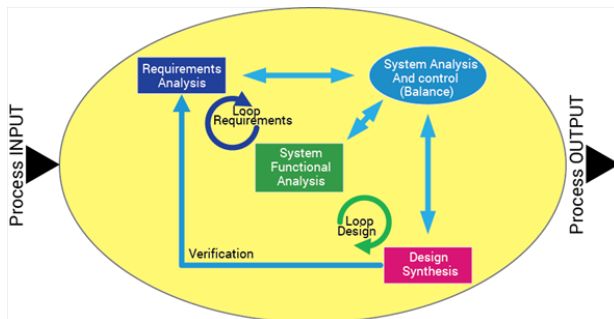

Fig. 2. Product life cycle development performed through the MBSE.

Those *architecture frameworks* are often applied to write directly the system requirements, despite the MBSE approach, which identifies the *customer needs* before the *requirements*, which are directly imported into the *digital model* of the system. The digital model allows *allocating*, *verifying* and *validating* the requirements, through an iterative

refinement, until that a complete correspondence between the product and the customer needs is found (Fig.2).

Converting the commitment into a digital model assures a *standard language*, and is linked to the *numerical models* developed during the design activity, thus bringing the customer to provide a clear information about the needs, in tight collaboration with the manufacturer.

### IV. REQUIREMENT ANALYSIS AND CUSTOMER NEEDS

#### A. Customer needs and commitment

According to the MBSE, the customer needs are preliminary detected, as a list of items, not yet written according to standards, like the MIL-STD 901. It is helpful distinguishing *needs* into four categories. Some are real *exigencies of customer*, others are *constraints related either to the technical standards* or *typical of the technical domain*. Sometimes they represent some exigencies related to the *manufacturing practice*. Finally, some are key issues to innovate the product (i.e. *innovation targets*) [5]. The priority of needs is perceived in different ways, depending on the category. It is higher for the customer needs and the technical standards, and strategic, but somehow negotiable, in case of the domain practices and the innovation targets.

Some *main goals* are even detected, as in the test case designing a lighter system, capable of assuring a target tracking despite the dynamic behavior of the ship, covered by a stealth shield, and equipped with a fast and reliable ammunition system. Among the *domain constraints* it is required to apply a *proprietary technology*, while having the ammunition system above the deck plane is an *innovation target*. It is worthy noticing that a representation of needs, as in Fig.3, allows realizing the balance between innovation and tradition, in the system development, simply by comparing the number of needs related to each category and the related *source*.

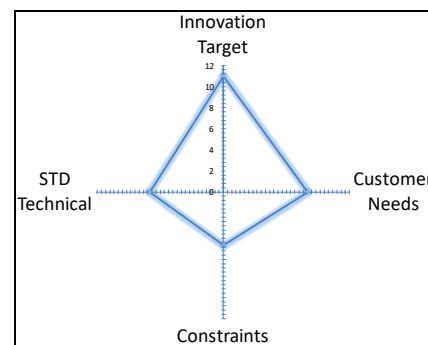

Fig. 3. Analysis of needs and related sources, for the detection of the level of innovation applied, in test case.

#### B. Requirements

A key issue in the requirement analysis is the classification, defined by the manufacturer, according to the technical domain and practice. A preliminary *classification* includes functional, operational and physical (or structural) requirements [6]. In this case a further level of classification is required. A distinction is even made between functional and non-functional or “dysfunctional” requirements, i.e. between a *nominal system configuration* working in operation and a *damaged configuration*, in which some *failures modes* occurred. Some specific items are then considered, like operational, physical, safety, maintenance and performance

requirements. Within those classes, some interfaces, environmental conditions and power supplies are considered. The caliber of the gun is even fixed, as well as the rates of training and elevation motion. A significant step consists in writing all the requirements through a *manager tool*, like the IBM DOORS®, to allow then an easy synchronization within the *functional model* developed by resorting to the IBM RHAPSODY®, which implements the SysML language. As a relevant result of this step the classification of requirements is assessed, as in Fig.4.

ID	Requirement
STR1	<b>1 Operative Requirements</b>
STR2	1.1 Operational need definition
STR3	1.2 System mission analysis
STR4	1.3 Operational sequences
STR5	1.4 Condition/Events to which a system must respond
STR6	1.5 Mission Performance Requirements
STR7	1.6 Maintenance and Reliability
STR8	1.7 User and maintainer roles
STR9	<b>2 Functional Requirements</b>
STR10	2.1 System Function
STR11	2.2 System Performances
STR12	2.3 Task or Action to be Performed
STR13	2.4 Inter-Function relationship
STR14	2.5 Hardware and software functional relationships
STR15	2.6 Performance Constraints
STR16	2.7 Interface requirements including identification or potetial open system opportunities
STR17	2.8 Unique hardware or software
STR18	2.9 Verification requirements
STR19	<b>3 Physical Requirements</b>
STR20	3.1 System physical Limitation
STR21	3.1.1 Physical Limitation
STR22	3.1.2 Technology limitations
STR23	3.1.3 Government Furnished Equipment (GFE), Commercial-Off-the-Shelf (COTS), Nondevelopmental Items (NDI), Reusability Requirements
STR24	3.1.4 Necessary or Directed Standards
STR30	3.2 Characterization of User
STR31	3.2.1 Handicaps
STR32	3.2.2 Constraints
STR25	3.2.3 Configuration System
STR26	3.3.1 Interface Description
STR27	3.3.2 Characteristics of information display and operator control
STR28	3.3.3 Relationships of operators to system/physical equipment
STR29	3.3.4 Operator skill and levels required to perform to assigned functions

Fig. 4. Structure of requirements imported into the IBM DOORS® tool.

## V. FUNCTIONAL ANALYSIS

### A. Stakeholders and use cases

A significant enhancement in the system development is given by the functional analysis, developed by means of the SysML [7]. Several diagrams are drawn to describe the behavior of the system first, and then some candidate architectures. A first step defines the *stakeholders*, here the commander (or COMANDO – COMmand unit AND ship Operations), the weather, the sea (since it drops water over the NGS), the radar unit, the operator at the NGS (or user), the operator for maintenance (or manual operator), the power supply, and the deck (i.e. a platform connected to the ship body). According to the architecture frameworks above cited, some operating conditions or ‘use cases’ are detected, as they appear in the *Use Case Diagrams* (UCD) of Fig.5. The use cases are very important to identify the role of each stakeholder and the activities, to create then a consistent numerical simulation of the system dynamics, as the physical modeling is performed. A number of use cases is defined by the manufacturer (Fig.5).

In the “wait” case the system is connected to a power supply, without operating (in maintenance), while during the “start-up” it is brought to the “stand by”, during which it can be fed by ammunition, but is unable to shoot. “Ready” means that it can be trained and elevated, without shooting, being the main action of the case “operating”. It is worthy noticing that some *dysfunctional use cases* are even foreseen, as the “misfire”, being the self-recovering status reached after a lack of shot, and the “fault”, corresponding to a stand-by after that a dysfunction is detected, apart from the misfire.

“Maintenance” defines the condition of out of service, under maintenance, while “isolated” describes the complete disconnection from the power supply and the direct control for extraordinary maintenance. Finally, the “shutdown” brings the system to be switched off. Some extensions are even defined, as the “change barrel” for a substitution of the gun, “dry” to remove the sea water from the gun, “turn around” to describe an imposed rotation, and “compensate displacement” to describe the specific action of feedback control applied to the NGS motion, to compensate for the deck motion.

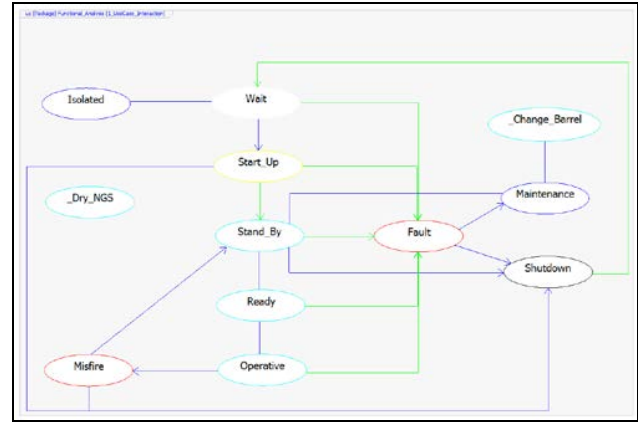

Fig. 5. The NGS use cases interactions as they appear in the IBM RHAPSODY® tool.

### B. Activities and States

For each use case, some related activities are described through the *Activity Diagrams* (AD). They allow realizing the sequence of actions to be performed, the interfaces between system and stakeholders, the components and subsystems to be used, like actuators, sensors, power supplies and other ones. All activities are described step by step, through a waterfall of diagrams, for a complete prediction of the logical operation of system, as in Fig.6, where a detail of the start-up activity is depicted.

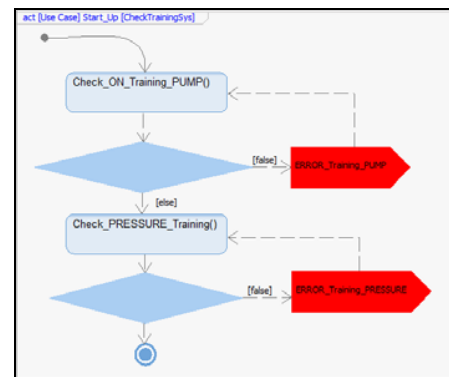

Fig. 6. Example of Activity Diagram drawn in the IBM RHAPSODY® tool for the “Start-up” of the NGS.

A preliminary system architecture is described through the *Block Definition Diagrams* (BDD), as in Fig.7, once that some AD and State Diagrams, describing the different states in which the system holds in each use case, were drawn.

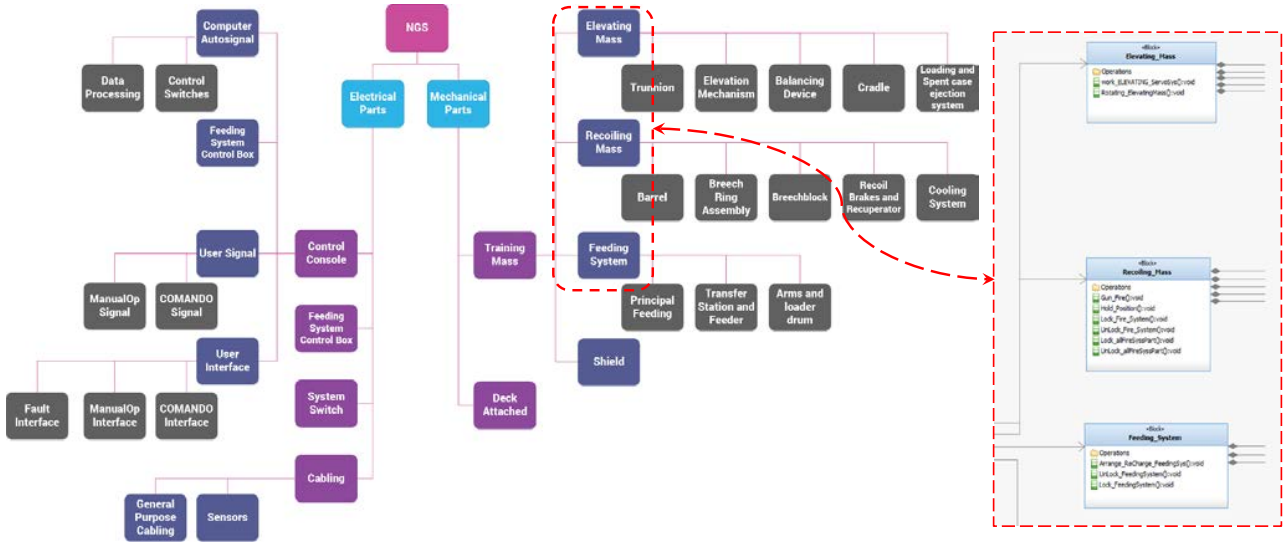

Fig. 7. Synthesis of the Blocks Definition Diagrams defined for the test case and example of the real implementation within the IBM RHAPSODY® (zoom).

### C. Requirements allocation

The previous step is relevant for the allocation of requirements, which are imported from the IBM DOORS® into the IBM RHAPSODY® model, through the gateway provided by the software. Particularly, the user activates some connections, between each block and the related function foreseen, within an AD and simultaneously between a block and the allocated requirement to define a *satisfaction* (for a given function there is a part satisfying the need), or either a *trace dependency* or a *refinement between requirements*, being related each other. This action allows importing the requirements inside the digital model of system, by connecting them to functions and blocks.

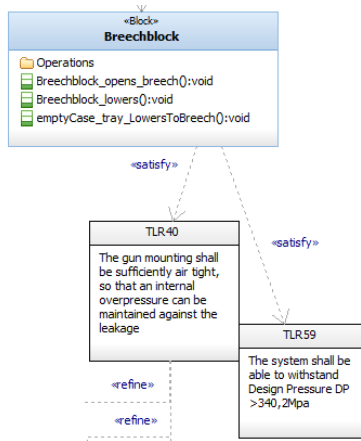

Fig. 8. Example of allocation of the requirements to blocks.

Moreover, the actual allocation of requirements is verified and the so-called *coverage of requirements* is automatically checked, to assure a full satisfaction, i.e. each requirement motivates the presence of a corresponding component. After the synchronization of requirements, a full representation of blocks, functions and requirements can be done as in Fig.8, and an immediate impression of the system *traceability* is provided. This step makes usually easier a complete allocation to the elements of some numerical models, which are exploited to predict the system dynamic behavior.

## VI. NUMERICAL MOCK-UP AND SIMULATION

### A. Numerical modeling

After the *functional view*, including only functions, and the *logical view* of system operation, describing some blocks, not yet associated to physical components, a *physical view*, aimed at defining the commercial components to be assembled is drawn. In this case, it is stated that two modeling activities are required. An *impression of the system configuration*, revealing the mass, volume and shape is needed to check the requirements related to the compatibility with the ship body and systems, respectively. A *dynamic model* has to be numerically solved, to predict the system response to the deck motion, under the active control command. Unfortunately, connecting immediately the functional model, developed in the IBM RHAPSODY®, to the SIMULINK® through the standard FMI as in [14] is impossible. A first allocation of blocks described by the BDD has to be performed, by drawing, for instance through the SOLIDWORKS® tool, each physical component, as in Fig.9.

The link between IBM RHAPSODY®, the SOLIDWORKS® and the SIMULINK® allows tracing and allocating the requirements to functions, and to the system components, described by a Part Number, and schematically sketched. The geometric model, built up in the SOLIDWORKS® environment, is then imported into the SIMULINK®, by means of the new tool SIMSCAPE®. It assures the importation of the system capabilities, by keeping the geometry, degrees of freedom, inertia and reference frames of the geometrical model. The SIMSCAPE® automatically decomposes the system into some SIMECHANICS® items, to be used for the dynamic simulation, as in Figs. 9 and 10. The SIMSCAPE® model can be directly connected to the SIMULINK® environment, thus allowing a preliminary selection of some typical design parameters of the whole system. Therefore, some assumptions in terms of material, geometry and characteristics of the joints between gun and tower, for instance, can be made, since the beginning, whilst the geometric model is drawn, or even associated to the parts, by forcing a simple attribution of numerical values to few design parameters, to assess then the best combination to be used for a detail design of components.



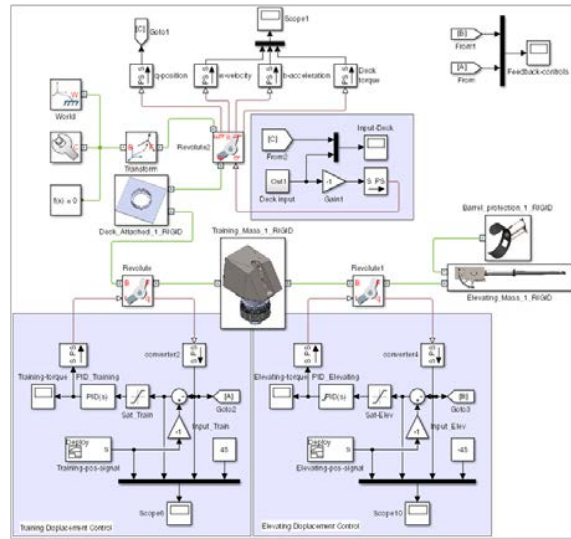
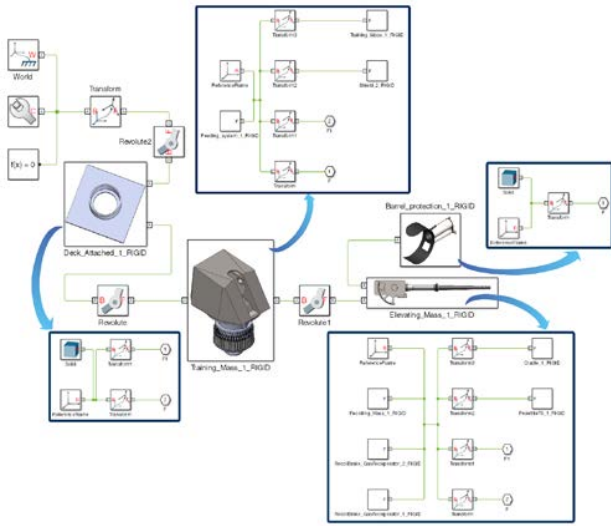

Fig. 9. The Simscape® (left side) and Simulink® (right side) models of the whole NGS system.

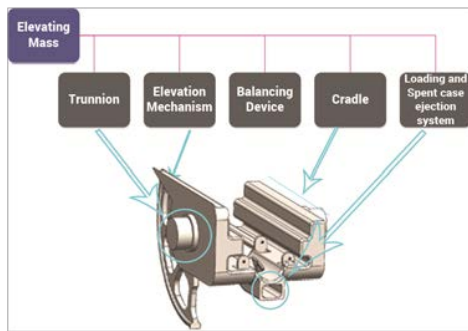

Fig. 10. Example of allocation of blocks to material and numbered parts.

### B. Numerical simulation and design synthesis

The virtual mock-up of the NGS can be tested, through a numerical prediction of the controlled dynamic behavior, in the SIMULINK®. Some typical maneuvers, foreseen by the MIL-STD Standards, for each use case, can be performed.

A main test concerns the dynamic response to a given profile of *roll motion* of the frigate ship, imposed to the deck as a dynamic input (Fig.11). In this case, the system is modeled as an assembly of rigid bodies, and only two degrees of freedom are considered, i.e. the *train* and the *elevation* angles. A feedback PID control is applied to the NGS, to operate the electric motors, governing the two motions, to constantly point the target. This strategy measures the error between the target point and the gun alignment. The Ziegler–Nichols approach [15] is applied to tune the PID parameters. For an inertia of 3000 and 3500 kgm<sup>2</sup> of the whole system, about the yaw and elevation axis, respectively, the related stiffness can be tentatively set at 180 and 90 MNm/rad, respectively [4]. The saturation angle for the training motion is fixed at  $-175^\circ$  to  $+175^\circ$ , while for the elevation motion spans from  $-27^\circ$  to  $+88^\circ$ . Some additional limitations are even applied to the train and elevation rates, although they are covered by the nondisclosure agreement.

The PID control gain is defined, as usual, as [15]:

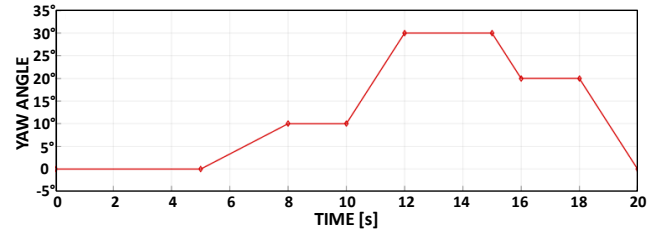

Fig. 11. Example of roll maneuver imposed to the ship deck to test the dynamic response of the controlled NGS.

$$G(s) = P + I \frac{1}{s} + D \frac{N}{1 + N \frac{1}{s}} \quad (1)$$

where  $P$ ,  $I$  and  $D$  are the proportional, integral and derivative contributions, while  $s$  is the Laplace coordinate, and  $N$  the control tuning parameter.

The electric motors to be applied to the two above mentioned motions are simultaneously selected among those commercially available and compatible with the installation on the frigate ship. To avoid the parasitic effect of the ship roll motion on the NGS maneuvers, the values of peak control torques found, by calculation, are 547 Nm for the training motion and 126 Nm for the elevation motion. They correspond to a request of additional power of 1231 W and 146 W, respectively. Those numerical results depend on how early the parasitic ship motion is detected. Nevertheless, this is linked to the specific system layout, i.e. on the location of the overall center of mass. To assure the system motion and target pointing, an AC Brushless motor fed by 760V/50Hz could be applied.

Other activities might be similarly performed to test some new layouts proposed for the ammunition system, but this part of the study is covered by the nondisclosure agreement. Nevertheless, the process applied looks similar to that previously described to refine the layout of the training and elevation systems.

As the example shows, the virtual mock-up implements the typical *functional simulation* performed within the MBSE to show the customer the *qualitative* performance of the system, but in this case the detail of the graphical

representation and the simplified physical modeling of the system provide a *quantitative* impression of the system geometry and dynamics. This preliminary design shall be surely refined and assessed. Nevertheless, it helps the customer either to accept or to reject the proposed layout. In the meanwhile, this judgement is reached with a complete awareness about the implications in terms of *requirements coverage* concerning each relevant detail of the tested system.

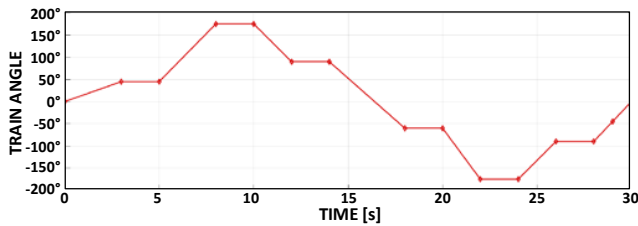

Fig. 12. Numerical prediction of training motion angular position.

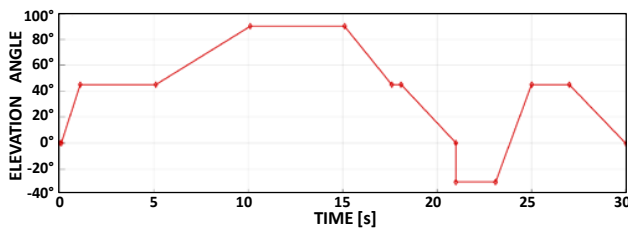

Fig. 13. Numerical prediction of elevation motion angular position.

## VII. SAFETY AND RELIABILITY

The process above implemented greatly helps in applying a new strategy for the analysis of the system safety and reliability. The practice of this technical domain suggests a Safety Assessment Process based on a Failure Hazard Analysis (FHA) and a System Safety Assessment (SSA), by resorting to the Failure Tree Analysis (FTA) and the Failure Mode and Effect Analysis (FMEA). This approach is applied to refine the requirements concerning reliability, availability, maintenance and safety (RAMS). In principle, the trade-off of the system configuration is an input for the following analyses, concerning the RAMS. Therefore, they are performed *a posteriori*, through the identification of several *failure modes*. This means that any eventual problem related to the RAMS analysis leads to a re-engineering operation.

The integrated heterogeneous simulation herein described adds another relevant benefit. It allows deploying the analysis of system *functions* and *dysfunctions* simultaneously, as the trade-off is performed. Particularly, it might be preliminarily realized that the *RAMS analysis* is definitely similar to the *functional analysis*. As it was described in [16] a perfect analogy can be found between the typical steps of the MBSE applied to the product development and those of a RAMS analysis, in terms of activities, products and tools involved. As Fig.14 describes, the dysfunctional analysis can be accomplished into three steps in sequence. The *Functional Hazard Analysis* (FHA) can detect the typical *failure conditions* of the operating system, exactly like the functional analysis defines its functions. Once that the failure modes are known, a first *reliability allocation* on the logical elements of the system architecture helps to define the *reliability targets*, which

drive the design to select the most suitable physical products. Finally, as the physical architecture is composed by selecting commercial components and subsystems, the *reliability prediction* of the system in service can be performed, by resorting to the reliability of commercial products declared and eventually tested.

This process is greatly improved by resorting to the AD, since they help in detecting the failure conditions applied to each function. It is simply required to negate each activity and to find the related effects, by following the links to the other activities, as it could be done in Fig.6.

In the test case a dysfunctional analysis is even driven by selected use cases like “misfire” and “fault”. They suggest the contents of the activities described in Fig.14, for the aircraft design [17], as in the tradition of this technical domain they lead to an easier definition of the FTA and FMEA.

Moreover, the failure conditions can be introduced as additional blocks in the *virtual mock-up*, based on the SIMULINK® model. Particularly, for each block the *nominal behavior* is described by the related equations, including some design parameters. An additional block, representing the failure modes and the related probability of occurrence, can be applied to the output of each block corresponding to a system component. Therefore, during the simulation, either the user or a probability function can activate a failure mode, to test its effects directly on the dynamic response of the NGS, as is currently done in other technical domains, like in aerospace engineering [17].

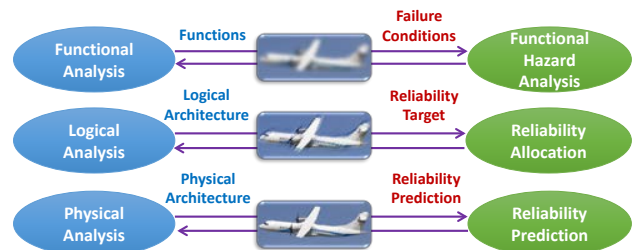

Fig. 14. Comparison and similitude between functional and RAMS analyses performed within the frame of the MBSE.

This approach is aligned with some contributions recently proposed and still under development, which formalize the definition of the tool chain applied to the so-called dependability assessment [18], through an integrated dysfunctional and numerical analysis [19], aimed at verifying the system requirements [20], even in case of systems of systems [21].

## VIII. CONCLUSION

The benefits of creating a *virtual mock-up* to be simulated through the MBSE *heterogeneous simulation* is here investigated. Particularly, the test case of a naval gun system simultaneously represents an example of full *mechatronic system* and of *product* developed on the basis of *architecture frameworks*, and described by a technical *commitment document*. Two needs characterize the technical domain involved. Performing the *trade-off* activity by exploiting a clear prediction of the *system dynamics* as well as a precise impression of the *system layout* is required. Anticipating to the trade-off activity the RAMS analysis, to

select the most reliable commercial products, to assembly the system is equally welcome.

The paper demonstrates that resorting to a *digital model*, including the system requirements, functions, and architecture, makes the communication between customer and designer clearer, faster and more effective, than a simple transmission of a verbal commitment document. The *traceability* and the *allocation* of requirements are better assured through the MBSE tools, provided that a suitable *interoperability of tools* is deployed.

An example of *virtual mock-up* making is provided. The requirement manager IBM DOORS® is easily linked to the functional model developed in the IBM RHAPSODY®, and then connected to the SIMULINK® model, once that a preliminary system drawing is done in the SOLIDWORKS® tool, through the SIMSCAPE® capabilities and dropped into the dynamic simulator. This approach allows a complete definition of the *tool chain*. A further development includes some additional blocks to integrate the *failure conditions* inside the dynamic simulator, for a faster *RAMS analysis*.

The originality of the proposed approach consists in providing a *visual representation* of the product under development, that the customer can evaluate in terms of volume, geometry, and layout, associated to a preliminary *dynamic simulation*, aimed to check the *system behavior*, its *performance* and even its *failure conditions*, when some additional blocks are included to predict the *system reliability*. This approach can be easily extended to other mechatronic systems, characterized by a controlled dynamics. A further development shall extend this strategy of *virtual mock-up* for the *heterogeneous simulation* even to some tools conceived for the *multibody dynamic analysis*, to predict the overall behavior of even more complex systems, as some *smart manufacturing systems*, applied in other technical domains [22].

#### REFERENCES

- [1] E. Crawley, B. Cameron, D. Selva. System Architecture: Strategy and Product Development for Complex Systems, Pearson, 2015.
- [2] D.D. Walden, G.J. Roedler, K. J. Forsberg, R. D. Hamelin, T.M. Shortell, The INCOSE Systems Engineering Handbook. Wiley, 4 ed., 2015.
- [3] A. Kossiakoff, W.N. Sweet, S.J. Seymour, S.M. Biemer, Systems Engineering Principles and Practice. Wiley-Interscience; 2 ed., 2011.
- [4] C.P. Chiarelli, Nozioni sui sistemi d'arma di artiglieria e missilistici, A.N. 2-35. Accademia Navale, 1994.
- [5] E. Brusa, D. Ferretto, A. Calà, "Integration of heterogeneous functional-vs-physical simulation within the industrial system design activity", Proc. IEEE ISSE 2015 Int. Symposium on Systems Engineering, Rome, September 29–30, 2015, pp.303-310.
- [6] E. Brusa, A. Calà, and D. Ferretto, Systems Engineering and Its Application to Industrial Product Development. Cham, Switzerland: Springer, 2018.
- [7] L. Delligatti, SysML Distilled: A Brief Guide to the Systems Modeling Language, Addison-Wesley Professional, 2013.
- [8] E. Brusa, A. Calà, S. Chiesa, F. De Vita, D. Ferretto, "Towards an effective interoperability of models within the 'Systems Engineering' applied to aeronautics". Proc. INCOSE Conf. on Systems Engineering (CIISE 2014), Rome, Italy, November 24-25, 2014, pp.38–47.
- [9] A. Mitschke, E. Brusa, A. Calà, D. Ferretto, C. Pessa, G. Bachelor, "Heterogeneous simulation based on standards: deepening interoperability in trade-off analysis approach for aeronautical application". Proc. 23<sup>rd</sup> Conf. Italian Ass. of Aeronautics and Astronautics, AIDAA 2015, 17-19 November 2015, Torino.
- [10] Mk 45 Naval Gun System. BAE System: www.baesystems.com
- [11] D.E. Wisnosky, J. Vogel, Dodaf Wizdom: a Practical Guide to Planning, Managing and Executing Projects to Build Enterprise Architectures using the Department of Defense Architecture Framework. Wizdom Systems, Inc., 2004.
- [12] MODAF, Guidance MOD Architecture Framework, <https://www.gov.uk/guidance/mod-architecture-framework>, 2012.
- [13] NAF, NATO Architecture framework, <http://nafdocs.org/introduction/>
- [14] E. Brusa, D. Ferretto, "Impact of the Model Based Systems Engineering on the design of a mechatronic flywheel-based energy storage system", Proc. IEEE ISSE 2016, Edinburgh, October 4–5, 2016, pp.171–178.
- [15] G.F. Franklin, J. Powell, A. Emami-Naeini, Feedback Control of Dynamic Systems, Pearson, 2014.
- [16] I. Vagliano, D. Ferretto, E. Brusa, M. Morisio, "OLSC based tool integration in the aerospace domain: an industrial case", Proc. IEEE COMPSAC 2017, Turin (Italy), 4-8 July, 2017.
- [17] C. Pessa, M. Cifaldi, E. Brusa, D. Ferretto, K. Malgieri, N. Viola, "Integration of different MBSE approaches within the design of a control maintenance system applied to the aircraft fuel system", Proc. IEEE ISSE 2016, Edinburgh, October 4–5, 2016, pp.120–127.
- [18] A. Tundis, M. Mühlhäuser, A. Garro, E. Brusa, D. Ferretto, "Dependability Assessment of a Deicing System through the RAMSAS method", Proc. IEEE Int. Symp. on Syst. Eng. ISSE 2017, Vienna, Austria, October 11-13, 2017.
- [19] A. Garro, J. Groß, M. Riestenpatt Gen. Richter, and A. Tundis, "Reliability Analysis of an Attitude Determination and Control System (ADCS) through the RAMSAS method", J. Computational Science, 5(3):439-449, 2014.
- [20] F. Aiello, A. Garro, Y. Lemmens, S. Dutré, "Simulation-based verification of system requirements: an integrated solution", Proc. 2017 IEEE 14<sup>th</sup> Int. Conf. on Networking, Sensing and Control (ICNSC 2017), Calabria, Italy, May 16-18, 2017.
- [21] A. Garro, A. Tundis. On the Reliability Analysis of Systems and Systems of Systems: the RAMSAS method and related extensions, IEEE Systems Journal, 9(1):232-241, 2015.
- [22] E. Brusa, S. Morsut, "Design and optimization of the Electric Arc Furnace structures through a mechatronic integrated modeling activity". IEEE - ASME Trans. Mechatronics, 20(3), June 2015, pp.1099–1107.