

Multi-cell Modelling Using Coloured Petri Nets Applied to Planar Cell Polarity

Qian Gao¹, Fei Liu³, David Tree², and David Gilbert¹

¹ School of Information Systems, Computing and Maths, Brunel University, UK
<http://www.brunel.ac.uk/siscm>

² School of Health Science and Social Care, Brunel University, UK
<http://www.brunel.ac.uk/about/acad/health/healthsub/bioscience>
{qian.gao,david.tree,david.gilbert}@brunel.ac.uk

³ Computer Science Department, Brandenburg University of Technology Cottbus,
Germany
<http://www-dssz.informatik.tu-cottbus.de/DSSZ>
liu@Informatik.tu-Cottbus.de

Abstract. Modelling across multiple scales is a current challenge in Systems Biology. In this paper we present an approach to model at different spatial scales, applied to a tissue comprising multiple hexagonally packed cells in a honeycomb formation in order to describe the phenomenon of Planar Cell Polarity (PCP).

PCP occurs in the epithelia of many animals and can lead to the alignment of hairs and bristles. Here, we present an approach to model this phenomenon by applying coloured Petri Nets (CPN). The aim is to discover the basic principles of implementing CPN to model a multi-cellular system with a hierarchical structure while keeping the model mathematically tractable. We describe a method to represent a spatially defined multi-scale biological system in an abstract form as a CPN model, in which all reactions within a cell are categorised into two main types, each cell is sub-divided into seven logical compartments and adjacent cells are coupled via the formation of intercellular complexes. This work illustrates the issues that need to be considered when modelling a multi-cellular system using CPNs. Moreover, we illustrate different levels of abstraction that can be used in order to simplify such a complex system and perform sophisticated high level analysis. Some preliminary analysis results from animation and stochastic simulation are included in this paper to demonstrate what kinds of sequential analysis can be performed over a CPN model.

Keywords: coloured Petri nets, modelling, planar cell polarity

1 Introduction

With the rapid growth of data being generated in the biological field, it has become necessary to organise the data into coherent models that describe system behaviour, which are subsequently used for simulation, analysis or prediction.

Modelling plays a crucial role in facilitating the understanding of complex biological mechanisms from an holistic viewpoint.

A large variety of modelling approaches have already been applied to model a wide array of biological systems (see [1] for a review). Among them, Petri nets are particularly suitable for representing and modelling the concurrent, asynchronous and dynamic behaviour of biological systems. Since Reddy et al. [2] introduced the application of qualitative Petri nets to modelling of metabolic pathways, a large variety of applications of Petri nets (e.g. stochastic Petri nets, timed Petri nets, continuous Petri nets, and hybrid Petri nets, etc.) have been developed for modelling and simulating different types of biological systems [3], [4].

Modelling across multiple scales is a current challenge in Systems Biology. There is the need to model at different spatial scales to describe, for example, intracellular locality in compartments, organelles and vacuoles, as well as intercellular locality in terms of intercellular communication by complex formation across cell gaps, and by cytokines (intercellular messengers), and higher levels of organisation into tissues and organs composed of many cells. However, standard Petri nets do not readily scale to meet these challenges, and current attempts to simulate biological systems by standard Petri nets have been mainly restricted so far to relatively small models. Standard Petri nets tend to grow quickly for modelling complex systems, which makes it more difficult to manage and understand the nets, thus increasing the risk of modelling errors. Two known modelling concepts improving this situation are hierarchy and colour. Hierarchical structuring has been discussed a lot, e.g. in [5], while the colour has gained little attention so far.

While there is a lot of reported work on the application of different classes of standard Petri nets to a variety of biochemical networks, see [4] for a recent review, there are only a few which take advantage of the additional power and ease of modelling offered by coloured Petri nets (CPN). To our knowledge, the existing applications of CPN in systems biology can only be seen in [6], [7], [8], [9], [10], [11], [12], [13]. Moreover, these existing studies usually resort to `Design/CPN` [14] or its successor `CPN Tools` [15] in order to model and analyse biological systems. However neither tool was specifically designed with the requirements of Systems Biology in mind. Thus they are not suitable in many aspects, e.g. they do not directly support stochastic or continuous modelling, nor the simulative analysis of the models by stochastic or deterministic simulation.

Building upon the lessons learnt so far, we extend our software tool Snoopy [16], [17] by specific functionalities and features to support editing, simulating and analysing of biological models based on coloured qualitative, stochastic and continuous Petri nets. By doing so, we not only provide compact and readable representations of complex biological systems, but also do not lose the analysis capabilities of standard Petri nets, which can still be supported by automatic unfolding. Moreover, another attractive advantage of CPN for a biological modeller is that they provide the possibility to easily increase the size of a model consisting of many similar subnets just by adding new colours.

Modelling in Biology tends to emphasise molecular details. Yet in biological networks that involve more than a few components the typical situation is that many details are unknown, and it is imperative to devise an approach that can be insightful and predictive even in the absence of complete knowledge. Our strategy was based on building an abstract model of PCP which attempts to identify the key biological aspects (e.g. formation of intercellular complexes), and then constructing a more detailed but simple model which parameterises the many unknowns.

In this paper, our aim is to use CPN to describe an intercellular and intracellular signalling model that replicates the phenomenon of PCP in *Drosophila* wing. The epithelial cells in this organ are hexagonally packed in a 2-dimensional honeycomb lattice. The model incorporates an abstract description of information flow within the cell, and a representation of inter-cellular communication through the formation of protein complexes, so that local (transmembrane) signalling produces a global effect over the entire organ. It should be noted that approach presented in this paper is applied to an abstract model of PCP in order to illustrate the application of CPN to PCP signalling. Specifically, we focus on the way to include the honeycomb structure and logical compartments into the construction of our multi-cellular model.

This paper is structured as follows: in Subsection 1.1 we introduced the biological background of planar cell polarity, followed by Subsection 1.2 briefly describing coloured Petri Nets and Section 2 describing our model and approaches, followed by the conclusion.

1.1 Planar Cell Polarity

Planar cell polarity (PCP) refers to the orientation of cells within the plane of the epithelium, orthogonal to the apical-basal polarity of the cells. This polarisation is required for many developmental events in both vertebrates and non-vertebrates. Defects in PCP in vertebrates underlie developmental abnormalities in multiple tissues including the neural tube, the kidney and the inner ear (reviewed in [18]). The signalling mechanisms underlying PCP have been studied most extensively in the epithelia of the fruit fly *Drosophila melanogaster* including the wing, the abdomen, the eye, and the bristles of the thorax. Genetic studies in the wing and eye in the 1990s led to the proposal of a PCP signalling pathway involving the PCP proteins Frizzled (Fz), Dishevelled (Dsh) and Prickle (Pk) (reviewed in [19]). In the late 1990s and 2000 further genetic analysis, including the discovery of more PCP proteins, e.g. Flamingo (Fmi) and Van-Gogh (Vang), and data on the sub-cellular localisation of these proteins in normal and mutant situations, have led to the formulation of more complex models of PCP signalling. In this paper we apply CPN to the models formulated in the fly wing as a means to gain insight into mechanism of PCP.

The adult *Drosophila* wing comprises about 300,000 hexagonal cells each of which contain a single hair which points in an invariant distal direction, see Figure 1. This hair comprises actin bundles and is extruded from the membrane at the distal edge of the cell during pupal development at the conclusion of

PCP signalling. Preceding this ultimate manifestation of PCP, PCP signalling occurs such that the proteins adopt an asymmetric localisation within each cell. At the initiation of PCP signalling Fmi, Fz, Dsh, Vang and Pk are all present symmetrically at the cell membrane. At the conclusion of PCP signalling Fmi is found at both the proximal and distal cell membrane, Fz and Dsh are found exclusively at the distal cell membrane and Vang and Pk are found exclusively at the proximal cell membrane. Through the interpretation of various genetic experiments a consensus view of the signalling events has been formulated that centres on the communication between these proteins at cell boundaries. The distally localised Fmi, Fz and Dsh recruit Fmi, Vang and Pk to the proximal cell boundary and vice versa. Since the localisation of the distal and proximal proteins appear to be mutually exclusive a completely polarised arrangement of protein localisation results. The PCP proteins are thus thought to mediate the cell-cell communication that comprises PCP signalling and that they are involved in establishing the molecular asymmetry within and between cells which is subsequently transformed into the polarisation of the wing hairs (reviewed in [20]). The result is a polarisation of individual cells and local alignment of polarity between neighbouring cells.

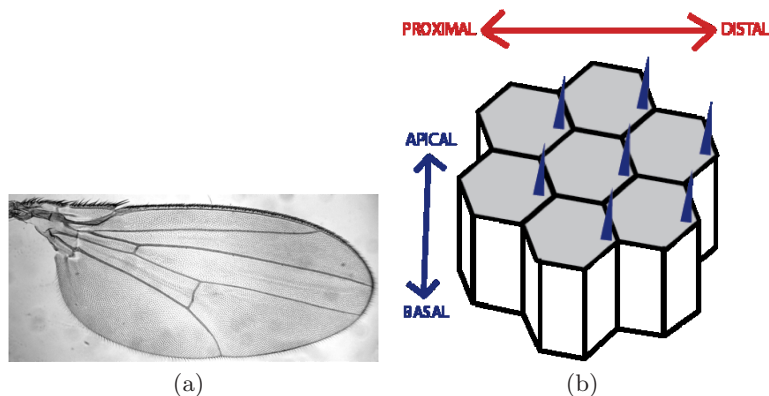

Fig. 1. *Drosophila*: (a) Whole wing; (b) Schematic of hexagonal cells with hairs

Systems biology and mathematical modelling have been applied to PCP signalling by Amonlirdviman et al. [21] (extended in [22]) and Le Garrec et al. [23] (applied to the *Drosophila* eye in [24]). Both models centre around the idea of amplification of polarity via asymmetric complex formation of the core proteins. Both models rely on numerical simulations in two dimensions for fields of hexagonal or approximately hexagonal cells. Therefore, they tend to be rather complex and do not lend themselves to mathematical analysis very easily. Furthermore, because of the lack of appropriate biological data, the feedback mechanisms in these models are mainly based on assumptions.

In this paper, we apply CPN to PCP signalling in a generic setting that encompasses a broad class of specific models, ranging from a single cell model to a multi-cellular model. To this end, we have developed an abstract model for the generation of PCP to investigate the signalling by implementing animation analysis and stochastic simulation analysis.

1.2 Coloured Petri Nets

Coloured Petri nets (CPN) [25], [26] are a discrete event modelling formalism combining the strengths of Petri nets with the expressive power of programming languages. Petri nets provide the graphical notation and constructions for modelling systems with concurrency, communication and synchronisation. The programming languages offer the constructions for the definition of data types, then used for creating compact models. This is the greatest advantage of CPN.

CPN consist, as do standard Petri nets, of places, transitions and arcs. In systems biology, places also represent species (chemical compounds) while transitions represent any kind of chemical reactions. Each place gets assigned a colour set and contains distinguishable coloured tokens. A distribution of coloured tokens on all places together constitutes a marking of a CPN. Each transition may have a guard, which is a Boolean expression over defined variables. The guard must be evaluated to true for the enabling of the transition if it is present. Each arc gets assigned an expression, which is a multiset type of the colour set of the connected place.

The variables associated with a transition consist of the variables in the guard of the transition and in the expressions of arcs connected to the transition. Before the expressions are evaluated, the variables must get values assigned with suitable data types, which is called binding [26]. A binding of a transition corresponds to a transition instance in the unfolded net. Enabling and firing of a transition instance are based on the evaluation of its guard and arc expressions. If the guard is evaluated to true and the preplaces have sufficient tokens, the transition instance is enabled and may fire. When a transition instance fires, it removes coloured tokens from its preplaces and adds tokens to its postplaces, i.e. it changes the current marking to a new reachable one. The colours of the tokens that are removed from preplaces and added to postplaces are decided by arc expressions. The set of markings reachable from the initial marking constitutes the state space of a given net. These reachable markings and instances of transitions between them constitute the reachability graph of the net.

Thus CPN has the ability to tackle the challenges arising from modelling biological systems beyond one spatial scale, for example, repetition of components, which is the need to describe multiple cells each of which has a similar definition; and organisation of components, which refers to how cells are organised into regular or irregular patterns over spatial networks in one, two or three dimensions.

In the following, we give the formal definition of CPN and briefly describe the tool for modelling CPN.

Definition In CPN, there are different types of expressions, arc expressions, guards and expressions for defining initial markings. An expression is built up from variables, constants, and operation symbols. It is not only associated with a particular colour set, but also written in terms of a predefined syntax. In the following, we denote by EXP a set of expressions that comply with a predefined syntax. The formal definition for coloured Petri nets is as follows [25], [26].

Definition 1 (coloured Petri net). *A coloured Petri net is a tuple $N = \langle P, T, F, \Sigma, C, g, f, m_0 \rangle$, where:*

- P is a finite, non-empty set of places.
- T is a finite, non-empty set of transitions.
- F is a finite set of directed arcs.
- Σ is a finite, non-empty set of colour sets.
- $C : P \rightarrow \Sigma$ is a colour function that assigns to each place $p \in P$ a colour set $C(p) \in \Sigma$.
- $g : T \rightarrow EXP$ is a guard function that assigns to each transition $t \in T$ a guard expression of the Boolean type.
- $f : F \rightarrow EXP$ is an arc function that assigns to each arc $a \in F$ an arc expression of a multiset type $C(p)_{MS}$, where p is the place connected to the arc a .
- $m_0 : P \rightarrow EXP$ is an initialisation function that assigns to each place $p \in P$ an initialisation expression of a multiset type $C(p)_{MS}$.

If we consider special arcs, e.g. read arcs or inhibitor arcs, we can get coloured qualitative (extended) Petri nets. If the transitions are associated with random (or deterministic) firing rates, we will get coloured stochastic (or continuous) Petri nets [17].

Modelling tool In Snoopy, we have implemented functionalities for editing, and animating/simulating coloured qualitative Petri nets (QPN^C), coloured stochastic Petri nets (SPN^C) and coloured continuous Petri nets (CPN^C) [17], [27]. In our implementation, QPN^C is a coloured extension of extended qualitative place/transition net (extended by different types of arcs, e.g. inhibitor arc, read arc, reset arc and equal arc [28]), SPN^C is a coloured extension of biochemically interpreted stochastic Petri nets introduced in [28] and [29], and CPN^C is a coloured extension of continuous Petri nets introduced in [28]. In this paper, the drawing, animation and simulation of coloured Petri net models for PCP are all done by Snoopy.

2 Modelling approach to apply CPN to PCP

We build an abstract model of PCP which only contains the key biological aspects and other relevant information which are essential for the construction of our models. Our study is obviously incomplete, as it does not explicitly identify all relevant genes and molecules, but it provides a useful framework permitting the future undertaking of further research to fulfil the understanding of PCP.

2.1 Abstract model of PCP

In this paper we model the dynamics of the regulatory protein network which controls PCP at two stages of refinement regarding the details of localisation and communication. In the first stage we represent the cell by a highly abstract model, encoded as a (non-coloured) Petri net. The second stage model is more refined and is encoded by a coloured Petri net. Both models describe the cytosol as well as the proximal and distal regions of the cell.

We assume that production of key signalling proteins occurs only in the cytosol and these are degraded constitutively throughout the cell. However, the proteins are distributed asymmetrically within the cell due to an internal transport network. *Drosophila* wing cells are approximately hexagonal and form a regular honeycomb lattice. The core machinery which controls PCP signalling is uniform across the *Drosophila* wing. Our model is an abstract description of PCP which includes only the key structure and biological aspects of PCP in order to establish the colour sets principles for each cell, and each compartment within a cell. Therefore, our abstract model is an extremely simplified version of PCP to begin with which only includes essential components and structure and eliminates the duplication of molecular species (places) at the distal and proximal edges of a cell. For example, Fz, Dsh, Pk and Vang exist at both edges of a cell but asymmetrically distribute at a particular edge of the cell, Fz and Dsh at the distal edge while Pk and Vang at the proximal edge. However, they occur only at the particular side of a cell in our abstract model in order to obtain a minimal simplified model which still satisfies the essential need to process the signalling. Thus, in our model, the polarity will be arisen by this asymmetrical distribution of proteins at the distal and proximal edges of each cell together with the intercellular communication. However the power of coloured Petri nets facilitates the construction of a large scale model of PCP in the wing, based on a pattern describing a single cell communicating with its neighbours.

2.2 Simple Petri net model for a single cell

We categorise all reactions involved in each cell into two main types: (1) production and transport of proteins; (2) transformation of proteins (reactions that process the signal). These describe the key biological aspects of PCP and also satisfy our requirement for a simple pattern model which can be used to establish CPN colours for the modelling problem. We firstly sub-divide each cell into four spatial regions: (1) the extracellular space (labelled as communication), where the intercellular complexes form, to the (2) proximal edge (left-hand side of each cell) in order to process intercellular signal between two adjacent neighbouring cells, (3) transport, and (4) distal (right-hand side of each cell). As a result, one cell contains five places (molecular species, *A*, *B*, *C*, *D*, *E*), three transitions (reactions, e.g. *r1*) and four spatial regions (e.g. proximal in the blue text box), see Figure 2 for details. In the model, places *D.left* and *E.left* indicate that these two molecular species are from the left-hand side neighbouring cell(s).

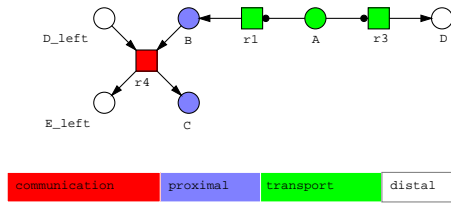

Fig. 2. Petri net model for a single cell: (a) Four spatial regions of a cell: they are labelled as communication, proximal, transport and distal; (b) Places (circle) and transitions (square): they are an abstract representation of the reactions involved in PCP. Production and transport of proteins is represented by places and transitions labelled in green, transformation of proteins is labelled in other colours. It should be noted that the labelled colours here do not provide any information about CPN coloursets, they are only used for demonstration purpose.

2.3 CPN model for pipeline of simple cells

Since PCP exhibits a high replication in terms of reactions and structure, we can simply use the single cell model from the first step as the pattern for the construction of our model of a pipeline of linked simple cells. Thus we create a model which is capable of folding any number of adjacent neighbouring cells using CPN in which a different colour is assigned for each individual cell.

We use the single cell model to start with and then assign a **constant** N to generate N adjacent cells. A **simple colour set** named CS with N colours is created to assign to each place, and a **variable** x with the type CS is assigned for each arc except the one from place D to transition $r4$, which gets the expression $[x > 1] - x$, read as "if x is greater than 1, then it will return the predecessor of x ", and meaning that the N cells are linked in a linear pipeline rather than a circuit, see Figure 3 for details.

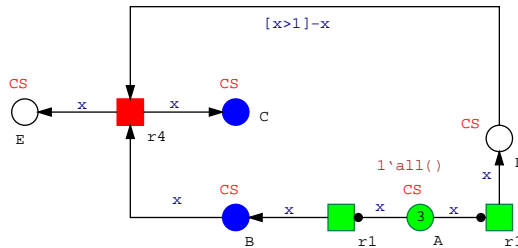

Fig. 3. CPN model for cells linked in a pipeline. The declarations are as follows: colourset $CS = \text{int}$ with $1 - N$, variable $x: CS$. The arc expression $[x > 1] - x$ indicates that the first cell is not linked to the last, meaning cells are linked in a linear pipeline.

2.4 Refined Petri net model for a single cell

Our refined model exploits the power of CPN to describe repeated structures, and is inspired by Noe et al. [30] who proposed the idea of compartmental kinetic modelling. As described in Section 1.1, the transmission of signalling mainly occurs at the distal and proximal edges of each cell, whereas, the cytosol only involves proteins production and transport. Thus, we need a central compartments to represent the cytosol and several compartments for the distal and proximal edge in each cell. Moreover, we does not consider the communication between the current cell and its north and south neighbouring cells in our model. As a result, we sub-divide each biological cell into seven *virtual compartments* (labelled as number 1, 2, ...7 in blue in Figure 4), three compartments each for the proximal and distal membrane edges, and one compartment for the cytosol, whilst each compartment involves all reactions in the single cell model. Here we aim to establish the framework of applying CPN to PCP signalling – this division of compartments is an initial approach, which will then be further developed in a more sophisticated manner if required. Because *Drosophila* wing cells form a regular honeycomb lattice there is the need to impose a hierarchical structure over the model, which we express as a regular hexagonal array of cells, each of which comprises seven virtual compartments, see Figure 4.

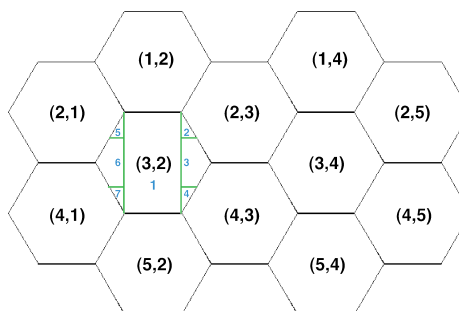

Fig. 4. Compartmentalised *Drosophila* wing epithelial cell in the context of a fragment of the wing tissue: (1) The coordinate in each cell represents the locality of its corresponding cell in the honeycomb lattice; (2) Each *virtual compartment* in a cell is labelled by number 1 to 7, illustrated by cell (3, 2).

Next we re-construct a Petri net model for a single cell by considering the seven virtual compartments (Figure 5). In this model, each place or transition belongs to a specific compartment, e.g. places *D* and *E* are located in three compartments 2, 3, 4 (labelled as *vc2*, *vc3*, *vc4* in Figure 5) .

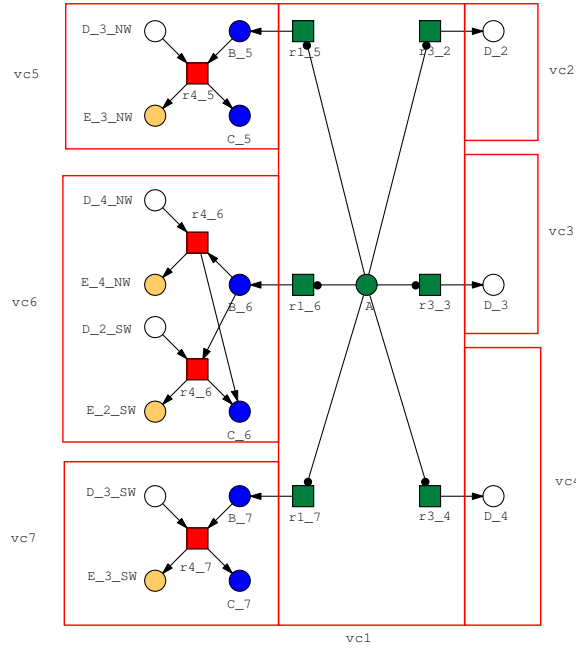

Fig. 5. Refined Petri net model for a single cell with seven compartments (labelled $vc1$, $vc2$, ..., $vc7$). Each place or transition belongs to a specific compartment, indicated by a number given as a suffix in place or transition names. *NW* and *SW* denote two left neighbours of the current cell.

2.5 CPN model for honeycomb lattice of refined cells

We now describe the construction of a CPN model for PCP with compartment division, following the procedure below.

First, we code cells of PCP as colours of a colour set, i.e. representing the locality of each cell using colours. We have chosen to model a 12-cell fragment of the wing tissue, see Figure 4, as this will give us an adequate size over which to explore the behaviour of our model. From the figure we can see that it is easy to use two-dimensional coordinates e.g. (x, y) to represent the cells in the rectangular honeycomb lattice, which can be defined by the compound colour set *product* in Snoopy. For this, we define two simple colour sets *Row* and *Column*, denoting the row and column of the lattice respectively, based on which we define a product colour set *CS1* to represent the coordinates of cells.

Second, we code the virtual compartments as colours. We do not represent them as numbers 1, 2, ..., 7 without considering their localisation within the cell, but use a matrix for compartments, i.e. by using a pair of coordinates (a, b) to denote the location of each compartment in the matrix so that we can clearly

distinguish between them. It should be noted that the middle compartment (cytosol) is represented as three rectangles in the matrix in order to conform with the overall matrix structure, whereas, only one colour set is used for this compartment rather than three colour sets.

Third, we create variables that are used in the guard of transitions and in the expression of arcs connected to transitions. In six virtual compartments for the proximal and distal edges, each arc has been assigned an expression which includes two pairs of coordinate (x, y, a, b) , meaning that the arc links the associated place to a particular transition in (a, b) compartment of (x, y) cell. In the middle virtual compartments, the arc expression changes to $(x, y, a + 1, 2)$ and $(x, y, a - 1, 2)$ which indicates the arcs which associate place *A* to transition *r1* in proximal (left-hand) compartments are denoted as $a + 1$, while, those link *A* to the transition *r3* in distal (right-hand) compartments are denoted as $a - 1$.

Next, we represent the neighbourhood between neighbouring cells. For this, we define two neighbour functions, *NW* and *SW*, denoting two left neighbours of the current cell.

Finally, we generate a CPN model for PCP, illustrated in Figure 6. See Table 1 for all declarations.

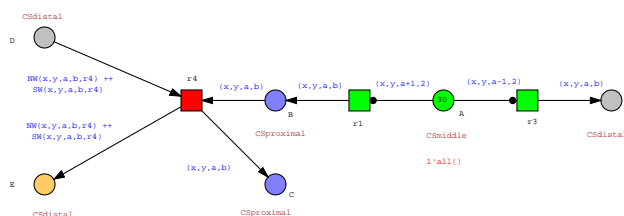

Fig. 6. CPN model describing cells with seven compartments in a 2-D matrix.

Based on what has been obtained from the above models, we will in the future be able to build a more sophisticated model of PCP which includes all detailed reactions according to our current understanding of the biological system. This will facilitate our ability to better understand mechanism of PCP signalling and provide reliable predictions to help guide the design of biological experiments which can help to fill in gaps in our knowledge of the system.

3 Analysis

CPNs enjoy a large variety of analysis techniques, ranging from informal animation or simulation to formal structural analysis or state space analysis. As the models constructed in this paper are still very abstract, we only use animation and stochastic simulation. The analysis reported here was performed on the model which comprises multiple cells and a matrix representing compartments within each cell.

Table 1. Declarations for the coloured Petri net model in Figure 6.

Declaration
colourset <i>Row</i> = int with 1 – <i>M</i> ;
colourset <i>Column</i> = int with 1 – <i>N</i> ;
colourset <i>ComR</i> = int with 1 – <i>R</i> ;
colourset <i>ComC</i> = int with 1 – <i>C</i> ;
colourset <i>CSr4</i> = enum with <i>c5</i> , <i>c6_1</i> , <i>c6_1</i> , <i>c7</i> ;
colourset <i>CS1</i> = product with <i>Row</i> × <i>Column</i> ;
colourset <i>CS2</i> = <i>CS1</i> with $x\%2 = 1 \& y\%2 = 0 \mid x\%2 = 0 \& y\%2 = 1$;
colourset <i>CS</i> = product with <i>Row</i> × <i>Column</i> × <i>ComR</i> × <i>ComC</i> ;
colourset <i>CS4</i> = <i>CS3</i> with $x\%2 = 1 \& y\%2 = 0 \mid x\%2 = 0 \& y\%2 = 1$;
colourset <i>CSdistal</i> = <i>CS4</i> with <i>b</i> = 3;
colourset <i>CSproximal</i> = <i>CS4</i> with <i>b</i> = 1;
colourset <i>CSmiddle</i> = <i>CS4</i> with <i>b</i> = 2;
variable <i>x</i> : <i>Row</i> ;
variable <i>y</i> : <i>Column</i> ;
variable <i>a</i> : <i>ComR</i> ;
variable <i>b</i> : <i>ComC</i> ;
variable <i>r4</i> : <i>CSr4</i> ;
constant <i>M</i> = int with 5;
constant <i>N</i> = int with 5;
constant <i>C</i> = int with 3;
constant <i>R</i> = int with 3;
function <i>CSproximal NW</i> (<i>Row</i> <i>x</i> , <i>Column</i> <i>y</i> , <i>ComR</i> <i>a</i> , <i>ComC</i> <i>b</i>);
function <i>CSproximal SW</i> (<i>Row</i> <i>x</i> , <i>Column</i> <i>y</i> , <i>ComR</i> <i>a</i> , <i>ComC</i> <i>b</i>);

3.1 Animation analysis

We first performed animation analysis (i.e. at the level of the token game) over our CPN model. Our expectation is that protein diffusion is fast. The relevant time-scale in this context is the typical time for diffusion of a membrane protein from one side of a cell to the opposite side which is of the order of 10 minutes. In comparison, the asymmetric pattern of protein localisation arises on a time scale of several hours. This is exactly what our model has shown when we manipulate automatic animation in Snoopy. Thus, it illustrates the reliability of applying CPN to model PCP.

3.2 Stochastic simulation analysis

We use the Gillespie stochastic simulation algorithm (SSA) [31] for the CPN model of PCP in Figure 6. Some of the results that have been produced over an interval of 180 per run are illustrated in Figure 8. The current understanding of the biological system is that the production of the hair is related to the concentration of several species, including actin which is believed to be responsible for the formation of the hair itself. We wish to validate our model by demonstrating that at an abstract level actin is concentrated at the most distal part of a

cell, designated as the future site for prehair formation. In our model, place E represents actin and other key proteins, distributed at the distal edge of the cell (virtual compartments $vc2$, $vc3$ and $vc4$) during signalling. Figure 7 shows how E changes over time in the three distal compartments ($vc2$, $vc3$ and $vc4$) of cell (3,4) and Figure 8 displays the final concentration of the coloured place E in virtual compartments $vc2$, $vc3$ and $vc4$ for each of the 12 cells (refer to Figure 4 for mappings). The results clearly show that the major accumulation of actin occurs in virtual compartment $vc3$ for each of the cells except for cells (2,5) and (4,5) which do not have distal neighbours and thus lack inter-cellular communication in that direction. The accumulation of actin in $vc3$ corresponds exactly to the location of the prehair formation at the most distal vertex of each cell, see Figure 1, and we find that it is highest in $vc3$ for cells (3,2) and (3,4) which have the maximum number of neighbouring cells (6 each) in the honeycomb lattice.

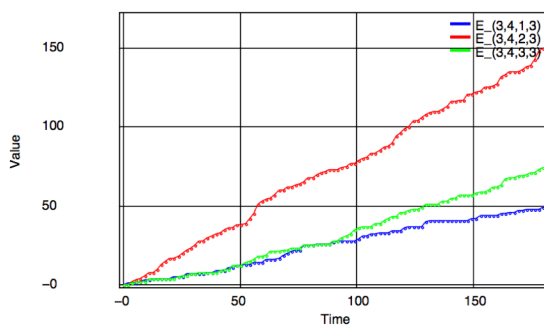

Fig. 7. Stochastic simulation result: time course plots for the value of E within cell (3,4) in the three virtual compartments $vc2$ (3,4,1,3), $vc3$ (3,4,2,3) and $vc4$ (3,4,3,3). Refer to Figure 4 for mappings.

		0			0
	72	(1,2) 97		69	(1,4) 77
(2,1) 135		49	(2,3) 148		45 (2,5) 0
	46		58	45	50
		(3,2) 168			(3,4) 170
	46		48	49	39
(4,1) 167		42	(4,3) 165		43 (4,5) 0
	76	(5,2) 88		68	(5,4) 84
		0			0

Fig. 8. Stochastic simulation result: final values for E in virtual compartments $vc2$, $vc3$ and $vc4$ for each of the 12 cells which are labelled by their identification tuple, refer to Figure 4 for mappings.

4 Conclusion

In this paper, we have presented our current work applying CPN techniques to construct a PCP model in order to explore the mechanisms that drive PCP. Our aim has been to provide a proof of principle for the use of CPN to model a multi-cellular system with a hierarchical structure while keeping the model mathematically tractable.

The model we have developed has allowed us to generate behaviours as a first step to explaining the complex behaviours observed in the biological system and to explore the implications of variations in the model. Our analysis confirms that the behaviour of the model correctly shows the major accumulation of actin occurring in the most distal part of the cell, corresponding to the location of the prehair formation in wing cells of *Drosophila*.

However, the ability of the current model to make predictions and provide an accurate picture of PCP signalling is limited by its lack of biological detail. In ongoing work we are refining this abstract model into a more detailed model, which includes exploring alternative ways in which to model the cellular machinery of PCP signalling. With this refined model we will be able not only to perform simulations of PCP signalling in wild-type cells but also on patches of mutant cells in a wild-type background. Our long term goal is to facilitate a better understanding of the mechanisms that drive PCP, and to make predictions about the behaviour of the system when it is perturbed by the mutation of specific genetic components.

References

1. Heath, A. P., Kavvaki, L. E.: Computational challenges in systems biology. *Computer Science Review*. 3 (1), 1-17 (2009)
2. Reddy, V. N., Mavrouniotis, M. L., Liebman, M. N.: *Petri Net Representations in Metabolic Pathways*. Proceedings of the 1st International Conference on Intelligent Systems for Molecular Biology. ISBN: 0-929280-47-4, vol. 328-336, pp. 9. AAAI Press (1993)
3. Gilbert, D., Heiner, M.: From Petri nets to differential equations - an integrative approach for biochemical network analysis. *Lecture Notes in Computer Science*. 4024,181-20 (2006)
4. Baldan, P., Cocco, N., Marin, A., Simeoni, M.: Petri nets for modelling metabolic pathways: a survey. *Natural Computing*. 9 (4), 955-989 (2010)
5. Marwan, W., Wagler, A., Weismantel, R.: Petri nets as a framework for the reconstruction and analysis of signal transduction pathways and regulatory networks. *Natural Computing*. Vol. 9 (2009)
6. Genrich, H., Kffner, R., Voss, K.: Executable Petri net models for the analysis of metabolic pathways. *International Journal on Software Tools for Technology Transfer*. 3 (4), 394-404 (2001)
7. Lee, D., Zimmer, R., Lee, S., Park, S.: Colored Petri net modeling and simulation of signal transduction pathways. *Metabolic Engineering*. 8, 112-122 (2006)
8. Peleg, M., Gabashvili, I. S., Altman, R. B.: Qualitative models of molecular function: linking genetic polymorphisms of tRNA to their functional sequelae. *Proceedings of the IEEE*. 90 (12), 1875-1886 (2002)

9. Tubner, C., Mathiak, B., Kupfer, A., Fleischer, N., Eckstein, S.: Modelling and simulation of the TLR4 pathway with coloured Petri nets. Proceedings of the 28th Annual International Conference of the IEEE Engineering in Medicine and Biology Society, pp. 2009-2012. IEEE, New York (2006)
10. Heiner, M., Koch, I., Voss, K.: Analysis and simulation of steady states in metabolic pathways with Petri nets. In: K. Jensen (ed) Proceedings of the Third Workshop and Tutorial on Practical Use of Coloured Petri Nets and the CPN Tools, vol. 29-31, pp. 15-34. University of Aarhus, Aarhus (2001)
11. Voss, K., Heiner, M., Koch, I.: Steady state analysis of metabolic pathways using Petri nets. In *Silico Biology*. 3, 0031 (2003)
12. Runge, T.: Application of coloured Petri nets in systems biology. In: AarhusK Jensen (ed) Proceedings of the fifth Workshop and Tutorial on Practical Use of Coloured Petri Nets and the CPN Tools, pp. 77-95. University of Aarhus, Aarhus (2004)
13. Bahi-Jaber, N., Pontier, D.: Modeling transmission of directly transmitted infectious diseases using colored stochastic petri nets. *Mathematical Biosciences*. 185, 1-13 (2003)
14. Christensen, S., Jrgensen, J. B., Kristensen, L. M.: Design/CPN - A Computer Tool for Coloured Petri Nets. Proceedings of the Third International Workshop on Tools and Algorithms for Construction and Analysis of Systems. LNCS 1217, pp. 209-223. Springer-Verlag London (1997)
15. Jensen, K., Kristensen, L. M., Wells, L. M.: Coloured Petri Nets and CPN Tools for Modelling and Validation of Concurrent Systems. *International Journal on Software Tools for Technology Transfer*. 9 (3/4), 213-254 (2007)
16. Rohr, C., Marwan, W., Heiner, M.: Snoopy - a unifying Petri net framework to investigate biomolecular networks. *Bioinformatics*. 26(7), 974-975 (2010)
17. Liu, F., Heiner, M.: Colored Petri nets to model and simulate biological systems. *Int. Workshop on Biological Processes and Petri Nets (BioPPN)*, satellite event of Petri Nets 2010. Braga, Portugal (2010)
18. Simons, M., Mlodzik, M.: Planar cell polarity signaling: From fly development to human disease. *Annu. Rev. Genet.* 42, 517-540 (2008)
19. Wong, L.L., Adler, P.N.: Tissue polarity genes of drosophila regulate the subcellular location for prehair initiation in pupal wing cells. *J. Cell Biol.* 123, 209-220 (1993)
20. Strutt, D.I.: Asymmetric localization of frizzled and the establishment of cell polarity in the drosophila wing. *Mol. Cell.* 7, 367-375 (2002)
21. Amonlirdviman, K., Khare, N.A., Tree, D.R.P., Chen, W.-S., Axelrod, J.D., Tomlin, C.J.: Mathematical modeling of planar cell polarity to understand domineering nonautonomy. *Science*. 307, 423-426 (2005)
22. Raffard, R.L., Amonlirdviman, K., Axelrod, J.D., Tomlin, C.J.: An adjoint-based parameter identification algorithm applied to planar cell polarity signaling. *IEEE Trans. Automat. Contr.* 53, 109-121 (2008)
23. Le Garrec, J.F., Lopez, P., Kerszberg, M.: Establishment and maintenance of planar epithelial cell polarity by asymmetric cadherin bridges: A computer model. *Dev. Dyn.* 235, 235-246 (2006)
24. Le Garrec, J.F., Kerszberg, M.: Modeling polarity buildup and cell fate decision in the fly eye: Insight into the connection between the PCP and Notch pathways. *Dev. Genes Evol.* 218, 413-426 (2008)
25. Jensen, K.: Coloured Petri Nets and the Invariant-Method. *Theor. Comput.* 14, 317-336 (1981)
26. Jensen, K., Kristensen, L. M.: Coloured Petri nets. Springer (2009)

27. Liu, F., Heiner, M.: Computation of Enabled Transition Instances for Colored Petri Nets. Proc. 17th German Workshop on Algorithms and Tools for Petri Nets (AWPN 2010), [CEUR-WS.org](http://www.ceur-ws.org). CEUR Workshop Proceedings, vol. 643, pp. 51–65, <http://ftp.informatik.rwth-aachen.de/Publications/CEUR-WS/Vol-643/paper05.pdf> (2010)
28. Gilbert, D., Heiner, M., Lehrack, S.: A unifying framework for modelling and analysing biochemical pathways using Petri nets. LNCS/LNBI. 4695, 200-216 (2007)
29. Heiner, M., Lehrack, S., Gilbert, D., Marwan, W.: Extended Stochastic Petri Nets for Model-based Design of Wetlab Experiments. Transaction on Computational Systems Biology XI. LNCS/LNBI. 5750, 138-163 (2009)
30. Noe, D.A., Delenick, J.C.: Quantitative analysis of membrane and secretory protein processing and intracellular transport. *J. Cell Sci.* 92, 449-459 (1989)
31. Gillespie, D T.: Exact stochastic simulation of coupled chemical reactions. *Journal of Physical Chemistry.* 81 (25), 2340-2361 (1977)